

# TM250

## Traffic Monitor

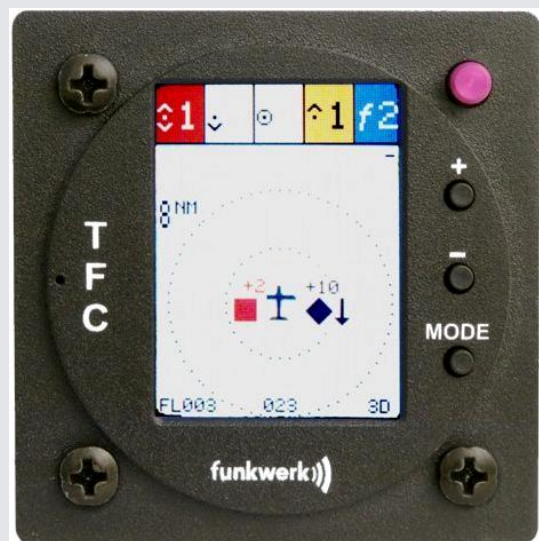

P/N 250TM-(xxx)-(xxx)

# Operation and Installation

(Dokument-Nr. 03.310.010.71e)



### List of Changes

Revision	Date	Change description
1.00	11.06.2009	First issue
1.01	21.07.2009	Visual Alerting
1.02	29.07.2009	Manual Setting of the ICAO 24-bit address, Software-Update by users
1.03	17.08.2009	Added Wiring Diagram (4.2)
1.04	30.07.2010	New Human Machine Interface Added information on connectors
1.05	28.01.2011	FLARM <sup>®</sup> Target Counter, automatic detection of external FLARM <sup>®</sup> device
1.06	31.03.2011	Pictures updates (2.1)
2.00	04.04.2012	Software 2.0 with Mode AC- functionality
2.01	01.04.2013	CE Declaration of Conformity adapted
2.10	24.06.2013	Software 2.1 - additional traffic protocol
3.00	04.02.2014	Change of company name to f.u.n.k.e. AVIONICS GmbH
3.01	05.08.2014	Adjusted the Audio Alert Mode-C; Added information to log output Tfc Tx; Added level of analog-line audio-out

### List of Service Bulletins (SB)

Service bulletins are to be inserted in the manual and to be recorded in the table.

SB Number	Rev. Nr.	Issue date	Date of Insertion	Name

### Device overview

Article number	Description
P/N 250TM-(000)-(000)	Basic variant
P/N 250TM-(100)-(100)	New HMI, Connection for external displays

## Table of Contents

1	Introduction .....	5
1.1	Symbols .....	5
1.2	Customer Service.....	5
1.3	Device Overview .....	6
2	Operation .....	9
2.1	Operation Controls .....	9
2.2	Switching On/Off .....	10
2.3	Traffic Display .....	10
2.3.1	Layout of the Traffic View .....	10
2.3.2	Symbols and Representations of the Traffic View .....	11
2.4	Configuration Page .....	14
2.4.1	Audio .....	14
2.4.2	FLARM® .....	16
2.4.3	Mode S .....	16
2.4.4	Mode C .....	16
2.4.5	Display .....	17
2.4.6	Filter .....	17
2.4.7	Traffic Transmit - Tfc Tx .....	18
2.4.8	Demo.....	19
2.5	ICAO Configuration Page.....	20
2.6	Information Page.....	22
2.7	Output of traffic data.....	23
2.8	Software Update .....	23
3	Installation.....	24
3.1	Unpacking and Inspection.....	24
3.2	Scope of Delivery .....	24
3.3	Mounting .....	25
3.4	Connectors .....	26
3.4.1	GPS Antenna .....	26
3.4.2	1090MHz / FLARM® Antenna.....	26
3.4.3	USB.....	27
3.4.4	Power / RS-232.....	27
3.5	Device Dimensions .....	29
3.5.1	Housing .....	29
3.5.2	Installation Tips .....	30
3.6	Post-installation Checks.....	30
3.7	Accessories .....	31

---

4	APPENDICES.....	32
4.1	Technical Data .....	32
4.2	Wiring Diagram .....	33
4.2.1	Cable Harness for TRT-Serie (XPDR).....	33
4.2.2	Cable Harness for OEM-device (XPDR) .....	34
4.3	Threat Classifications – Zone Division .....	35

## 1 INTRODUCTION

This manual contains information about the physical, mechanical and electric characteristics and instructions on installation and operation of the traffic display TM250.

### 1.1 Symbols

	Vital information that if not followed may cause damage in the device or in other parts of equipment or may have a negative impact on the correct function of the device.
---	---

	Information
--	-------------

### 1.2 Customer Service

For fast handling of returns please follow the instructions on the form for complaints and returns provided in the service area of the f.u.n.k.e. AVIONICS GmbH website [www.funkeavionics.de](http://www.funkeavionics.de).

	Suggestions for the improvement of our manuals are welcome. Contact: <a href="mailto:service@funkeavionics.de">service@funkeavionics.de</a> .
---	---

	Information about software updates is available from f.u.n.k.e. AVIONICS GmbH.
---	--

### 1.3 Device Overview

The traffic display TM250 by f.u.n.k.e. AVIONICS GmbH is aimed at supporting air space surveillance for General Aviation. It integrates Mode S, ADS-B, and FLARM<sup>®</sup>-Detection in one single device for cockpit installation.

#### ADS-B, Mode S and Mode AC

ADS-B (Automatic Dependent Surveillance – Broadcast) means that airplanes whose Mode S transponder is coupled with a GPS receiver emit their position data on the frequency 1090 MHz. This data can be received by all airspace users in a vicinity of up to approx. 150 NM. These ADS-B transmissions from other airplanes are decoded by the built-in Mode S receiver in the TM250. The display of the TM250 indicates the relative position of these airplanes as well as their vertical movement direction. This allows a quick assessment of the traffic situation.

Today, the majority of Air Transport airplanes are equipped with ADS-B capable systems. Because General Aviation still has a relatively low degree of ADS-B equipage, airplanes whose transponders do not send out ADS-B signals are also detected by the TM250. This is achieved through evaluation of the field strength of the Mode S and Mode AC signals. In this case, the proximity of such airplanes is signalled by the TM250 graphically and acoustically. However, a representation of direction or position of these airplanes is not possible.

The TM250 includes a built-in GPS receiver and can transmit its position data via an additional serial interface to an ADS-B capable Mode S transponder (such as the TRT800A/H). Such an installation forms a complete ADS-B system that can receive and transmit position data through ADS-B and contributes therefore actively to flight safety.

#### FLARM<sup>®</sup>

Nowadays, numerous glider aircraft are equipped with so-called FLARM<sup>®</sup> systems for collision avoidance. Via a serial interface, an external FLARM<sup>®</sup> receiver can be connected to the TM250 which then allows indicating the position and movement direction of these airplanes on the display of the TM250.



In case an external FLARM<sup>®</sup> is connected, the FLARM<sup>®</sup> alert will automatically be disabled (see 2.4.2), in order to avoid permanent alerting. This does not impact the display of FLARM<sup>®</sup> targets. FLARM<sup>®</sup> targets will still be displayed.

If the aircraft does not carry such a FLARM<sup>®</sup> receiver connected to the TM250, other gliders nearby that have a FLARM<sup>®</sup> transmitter can still be detected and indicated on the TM250 graphically and acoustically. This is achieved through a raw, non-directional detection of the signal strength of a nearby FLARM<sup>®</sup> transmitter inside the TM250. In this case, however, it is not possible to indicate the direction, distance, altitude, or position of such targets. Also, no transmission to other gliders occurs.

For traffic display and warning, four different types of targets are distinguished depending on the respective equipment of these aircraft.

### 1. FLARM<sup>®</sup> targets

Aircraft, particularly gliders, with a FLARM<sup>®</sup> system: As long as no external FLARM<sup>®</sup> receiver is connected to the TM250, the recognition of the FLARM<sup>®</sup> equipped airplanes is based merely on the detection of the signals, and will be shown in the counter, but not on the “map”.

Due to their low radio transmission power, FLARM<sup>®</sup> targets can only be detected in smaller distances than the other target types.

### 2. Mode S targets

Aircraft with a Mode S transponder without ADS-B "out" function (not "extended squitter" capable): The Mode S Transponder sends out the ICAO 24bit address that allows identifying the transmitter. A rough estimate of distance and approach rate of each transponder is determined by measuring the field strength of these transmissions.

### 3. Mode AC targets

Aircraft with non-Mode-S-capable (older) transponder: The transponder-transmissions contain either the altitude (Mode C) or the Squawk (Mode A). It is technically not possible to always distinguish between these two transmissions – for safety reasons, in these cases the information is always interpreted as altitude, what may lead to unnecessary warnings. As additionally the AC transmissions do not contain the 24bit address of the Mode S signal, it is not impossible, that one and the same aircraft, due to transmitting both Mode S and

**Operation and Installation**

Mode AC, is detected multiple times. A rough estimate of distance and approach rate of each transponder is determined by measuring the field strength of these transmissions.

**4. ADS-B targets**

For aircraft with a Mode S transponder that is ADS-B "out" capable: The position information transmitted by these aircraft can be used directly for the traffic display and for determination of dangerous proximities.





	<p>Some aircraft will not be detected at all, as they have neither a transponder nor a FLARM<sup>®</sup> device activated.</p> <p>Other aircraft will be detected multiple times, due to the manifold signal evaluations – the theoretical maximum is a four-time detection (ADS-B, Mode S, Mode AC, FLARM<sup>®</sup>).</p>
---	--

	<p><b>This device is not a certified anti-collision warning system and may only be used as supportive means for airspace observation.</b></p> <p><b>The pilot is still obliged to observe the surrounding airspace and to comply with all applicable rules and regulations for safe flight operations..</b></p>
---	---

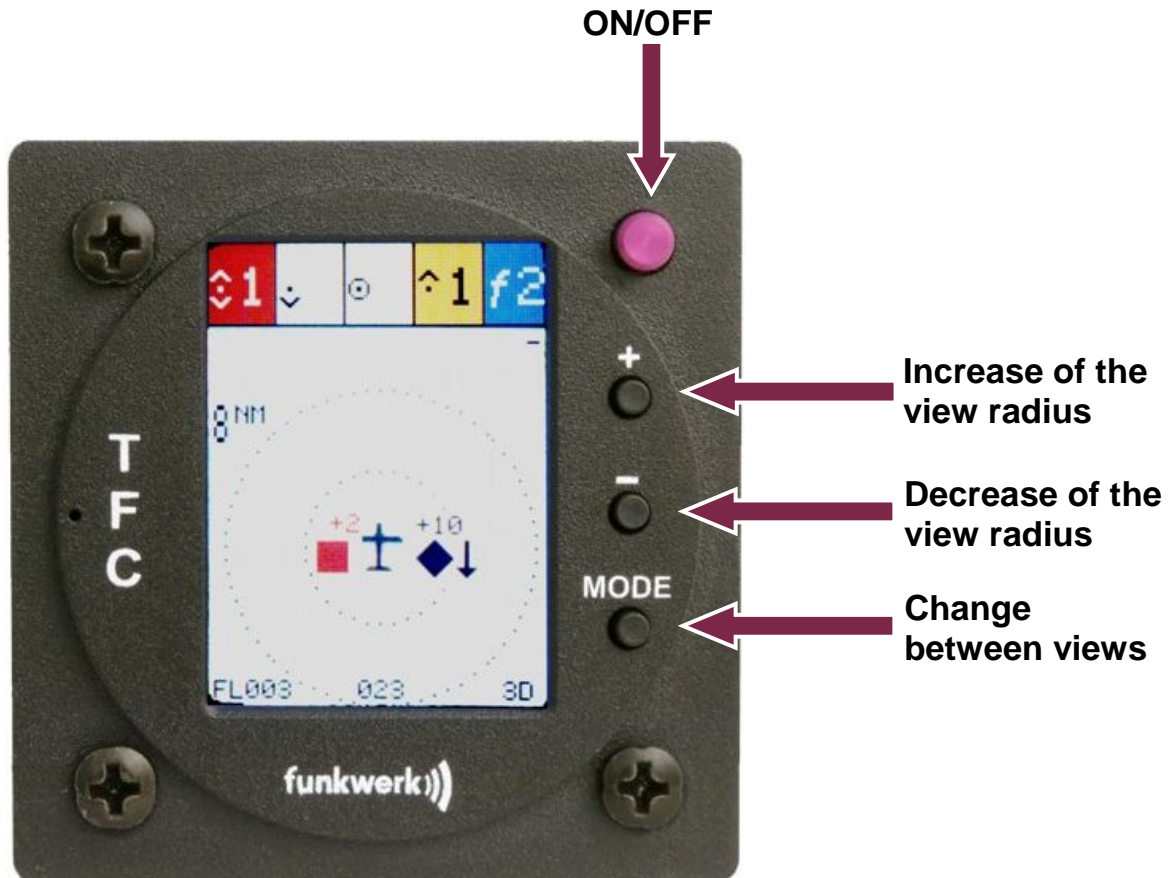
## 2 OPERATION

### 2.1 Operation Controls



	ON/OFF	<i>Power Switch</i>
	PLUS	1. <i>TFC view – increase of the view radius</i> 2. <i>SETTINGS – modification of values</i>
	MINUS	1. <i>TFC view – decrease of the view radius</i> 2. <i>SETTINGS – navigation through the menu (down)</i>
	MODE	<i>Change between the views TFC, SETTINGS, and INFO</i>

## 2.2 Switching On/Off

The device is turned on with the ON/OFF switch. After switching it on, the following indication is shown:



(Example)

Company logo (Example)

Software-Version (Example)

This announcement can be skipped over by pressing any key.

## 2.3 Traffic Display

After the initial start screen, the display changes to traffic view (TFC). Other available views are the configuration pages (SETTINGS) and the information page (INFO). Changing between these four views is done with the **MODE** key.

### 2.3.1 Layout of the Traffic View

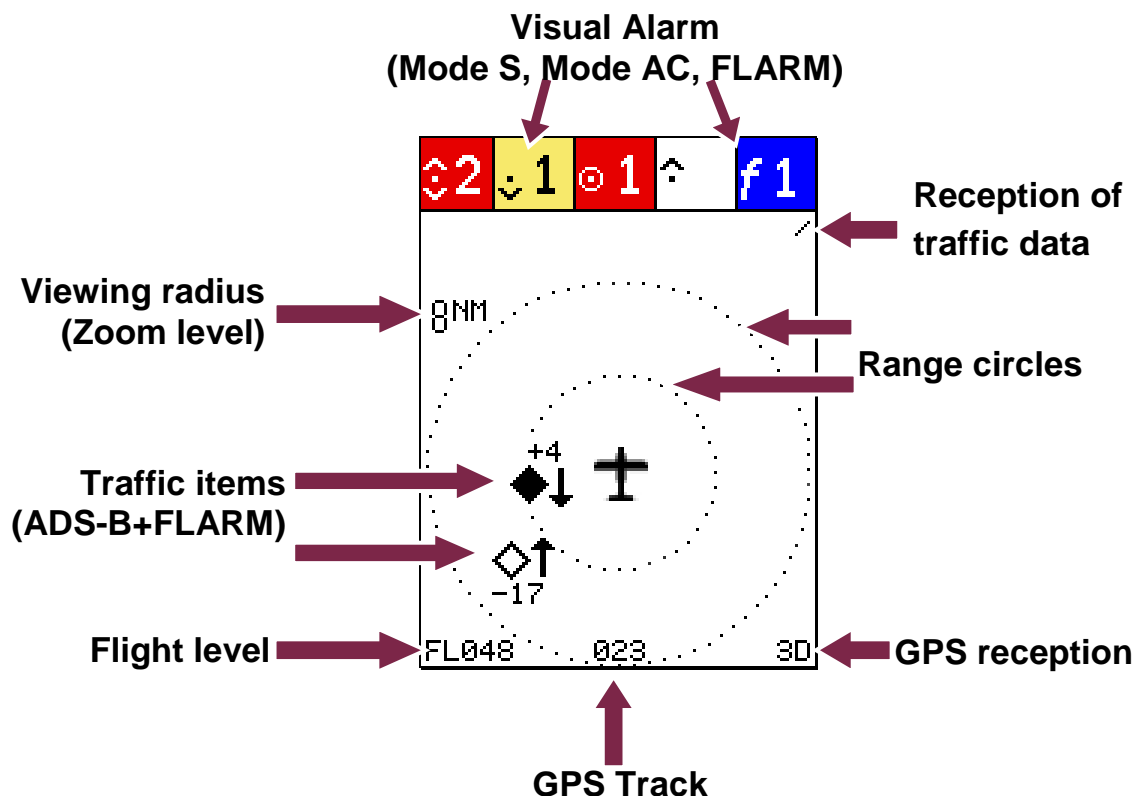







**Operation and Installation**



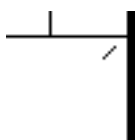
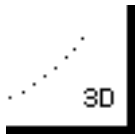
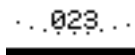





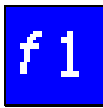

Around the own aircraft symbol there are two range circles that are always arranged in a way that the external one corresponds to the selected viewing radius. The inner range circle corresponds to half of the selected viewing radius.





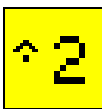

In the lower line, the current flight level, GPS track and the quality of GPS reception are indicated.

Other details of various representations and symbols are described in the following section.

**2.3.2 Symbols and Representations of the Traffic View**

Indication	Explanation	Remarks
 Rotating Bar	Reception of traffic data (FLARM®, Mode S or ADS-B)	Shown in the upper right corner of the display
	<u>GPS reception:</u> GPS: no GPS reception 2D: only horizontal position 3D: horizontal position and altitude	Shown in the lower right corner of the display
	GPS track	Current track as determined by the internal GPS module
	Flight level "NoFL" indicates that only GPS altitude is available	Based on barometric altitude (as transmitted by the own aircraft transponder in the ADS-B report)
	Viewing radius (zoom level)	Adjustable with  and  . Possible values are 1 NM, 2 NM, 4 NM, and 8 NM.
	Symbol of own airplane	

Indication	Explanation	Remarks
	External FLARM <sup>®</sup> device detected	The FLARM <sup>®</sup> targets will be displayed in the “map” view
	Number of FLARM <sup>®</sup> signals detected	At least one FLARM <sup>®</sup> transmitter is nearby (if no external FLARM <sup>®</sup> device has been connected)
	Number of Mode S and of Mode AC alarms <u>without</u> altitude information	The measured field strength exceeds threshold values
 	Number of Mode S and of Mode AC alarms <u>below</u> the own altitude The small triangle indicates possible multiple detection	These targets are 300 ft to 1200 ft below
 	Number of Mode S and of Mode AC alarms <u>in the same</u> altitude The small triangle indicates possible multiple detection	The relative altitude distance of these targets is less than 300 ft
 	Number of Mode S and of Mode AC alarms <u>above</u> the own aircraft The small triangle indicates possible multiple detection	These targets are 300 ft to 1200 ft above
	Traffic symbol without threat potential	
	Traffic symbol with direction indication without threat potential	
	Traffic symbol with approach alarm	For definition see 4.3

Indication	Explanation	Remarks
	Direction indicator with approach alarm	For definition see <b>Fehler! Verweisquelle konnte nicht gefunden werden.</b>
	Traffic symbol with <u>potential</u> collision threat	For definition see 4.3
	Direction indicator with <u>potential</u> collision threat	For definition see <b>Fehler! Verweisquelle konnte nicht gefunden werden.</b>
	Traffic symbol with <u>collision threat</u> - action required	For definition see 4.3
	Direction indicator with <u>collision threat</u> - action required	For definition see <b>Fehler! Verweisquelle konnte nicht gefunden werden.</b>
	<p>Symbol for ADS-B and FLARM<sup>®</sup> targets (if external FLARM<sup>®</sup> is connected):</p> <p>Traffic objects whose position is shown in relation to own position</p> <p>In addition, the relative altitude (flight level difference) and a trend arrow for climbing and descending are indicated.</p> <p>If own barometric altitude cannot be determined (because own Mode S Transponder does not support ADS-B) the absolute flight level is indicated instead of the relative flight level.</p>	<p>Depending on whether the traffic object is above or below own aircraft, the relative altitude will be shown above or below the symbol.</p> <p>If the target's climb or descent rate exceeds 500 ft/min an accordingly directed trend arrow is shown next to the symbol.</p>

## 2.4 Configuration Page

The configuration view may be selected by the use of the **MODE** Button.



The desired menu item can then be selected by one or multiple presses of the minus key **-**. Selection goes repeatedly from top to bottom. The blue background indicates the active menu item that can be adjusted with the **+** key. More details on each menu item can be found in the following segments.

### 2.4.1 Audio

In addition to the visual warnings audio alerts can also be raised. The following settings for when and how audio alerts will be raised are offered:

once..... For each traffic object, an audio alert is raised only once when it is recognized as a threat

repeat..... The audio alert continues as long as the target poses a threat or the user confirms (and thus silences) the alarm with the **+** or **-** key. Any alert needs to be confirmed separately. Depending on the threat level the audio alerts will be repeated every 4 seconds for the approach alarm, every 2 seconds for a potential collision threat and once per second for an active collision threat.

disabled ..... No audio alert is raised.

**Operation and Installation**

	<p>Changes made by the user in this setting area are only temporary. This means that after system reboot the standard setting “once” will be used again.</p>
---	--

Conditions for raising an audio alert differ depending on the type of traffic (FLARM<sup>®</sup>, Mode S, ADS-B). The following table shows the different conditions:

	Once	Repeat
<b>FLARM<sup>®</sup></b>	Warning tone sounds once as soon as a FLARM <sup>®</sup> signal is received. As long as the alarm stays active no further warning tone will sound.	The warning tone sounds repeatedly as long as the alarm is active or until it is confirmed by the user
<b>Mode S</b>	A warning tone sounds as soon as the field strength of a Mode S exceeds the selected threshold. Because a Mode S target can be identified by its 24 bit ICAO-address, the warning is only raised again when the target poses a threat again.	As long as the measured field strength of a target exceeds the thresholds, the warning tone sounds repeatedly. The warning tone can be confirmed (silenced) by the user.
<b>Mode C</b>	As for Mode S	As for Mode S
<b>ADS-B</b>	Each time an ADS-B object enters one of three protection zones, (horizontally 6 NM, 3 NM, 1.5 NM; vertically 1200 ft, 600 ft, 300 ft) a single audio alert is raised.	While an ADS-B object is within the protection zones, the warning tone sounds repeatedly until the target leaves the zone or the alert is confirmed by the user.

Acoustic warning hints are made of different sound schemes in order to specify the kind of threat in more detail:

**FLARM<sup>®</sup>**    short-short-short

**Mode S**        long-long

**Mode C**        long-short

**ADS-B**        long

Besides these acoustic warning signals, visual warnings can be configured as well (see following sections).

## 2.4.2 FLARM®

In case that at least one FLARM® equipped aircraft is too close to the own aircraft, the symbol “f” together with the number of targets will be displayed at the upper right display corner. This warning is based on the detection of the respective signals as transmitted by such aircraft. An alert stays active for at least 10 seconds, even if the target is detected only for a short period of time.

off..... switches off the warnings for FLARM® signals

on..... switches on the warnings for FLARM® signals

extern..... external FLARM® device detected



In case an external FLARM® is connected to the TM250, the FLARM® Alarm will be switched off automatically since otherwise a continuous alarm will happen. The depiction of the FLARM®-objects is not affected by this.

## 2.4.3 Mode S

The sensitivity for Mode S signals can be configured here.

off..... disables warnings for Mode S signals

high..... high sensitivity: With this setting, relatively weak Mode S signals can be detected.

low..... low sensitivity: Only relatively strong Mode S signals are taken into consideration

medium..... medium sensitivity: It is recommended to start with this setting and to adjust the sensitivity only when required.

## 2.4.4 Mode C

The sensitivity for Mode AC signals can be configured here.

The values are the same as for Mode S, see chapter 2.4.3.

### 2.4.5 Display

To reduce the display brightness it is possible to select a "Night" display mode. With this, black and white will be inverted, i.e. a formerly white background with black symbols now appears with white symbols on a black background. The remaining colour coding stays the same, only the background changes.

day..... Default setting

night..... Inverted representation of the display, used to reduce the brightness of the screen.

--	--

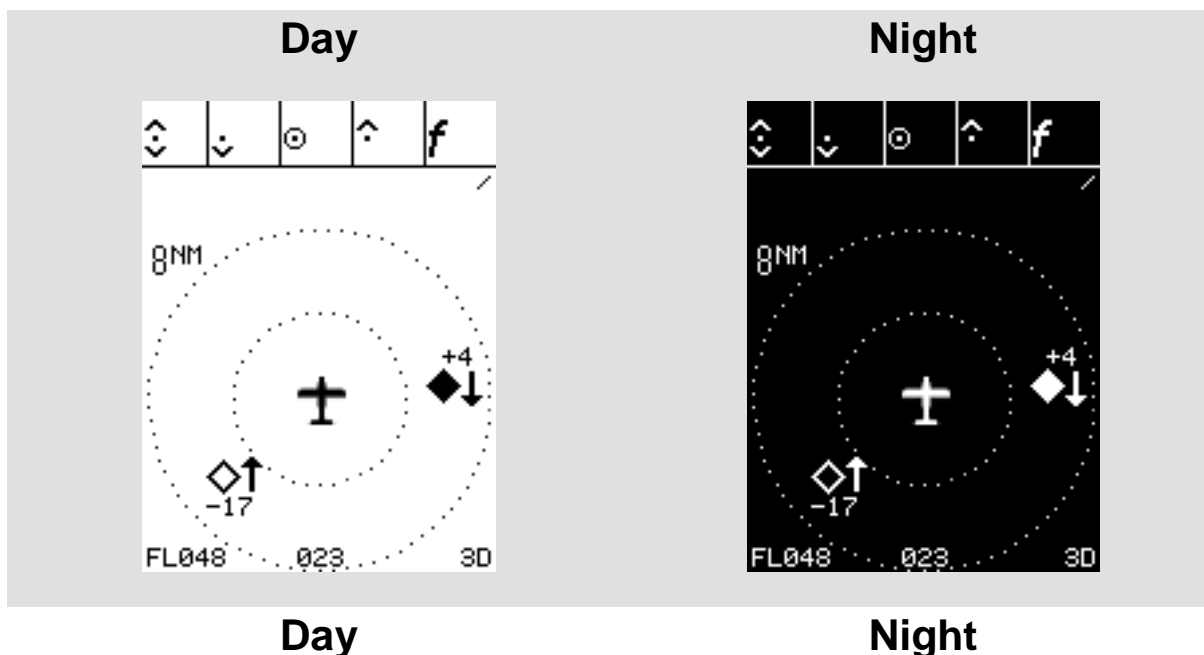

### 2.4.6 Filter

With this parameter, an altitude filter can be defined for ADS-B objects. This allows reducing the number of targets on the display in case of high traffic density so that only the most important information is shown.

off..... No filtering



1000 ft..... Indications and alerts are created only for ADS-B aircraft that are within 1000 ft below or above own barometric

**Operation and Installation**

altitude (which is provided by the own aircraft's ADS-B capable Mode S transponder)

2000 ft..... Indication and warning consider only aircraft that are within 2000 ft below or above own barometric altitude.

4000 ft..... Indications and alerts are created only for ADS-B aircraft 4000 ft below or above own barometric altitude.

	<p>These settings define only a vertical filter. The horizontal range is set directly as the view range with the  and  keys on the traffic view page.</p>
---	---

If no barometric altitude is available, e.g. because the own Mode S transponder is not ADS-B capable, the altitude determined by the GPS receiver is used for comparison. In the traffic view this is indicated by the missing flight level information ("No FL" in the left lower corner). In this case, relative altitude cannot be computed correctly (comparison of GPS with Barometric altitude). Therefore, only the absolute flight level of the traffic objects, marked by a preceding "FL", is indicated in this case.

**2.4.7 Traffic Transmit - Tfc Tx**

With the setting Tfc Tx, the output format can be set for additional connected display devices (moving map displays). See Section 2.7. Here are two supported formats:

- default      Use the setting "default" for devices which support the text-based protocol (pseudo FLARM®). at 19200 baud These include the SkyView® devices of DYNON and FlyMap® displays of Stauff Systemec.
- others        With "others" ADS-B traffic data can be sent to any device using a binary protocol at 9600 baud. In contrast to the "default" mode only ADS-B traffic is transmitted, but no Flarm® or Mode A/C and S.

	<p>If the binary protocol is selected for Tfc Tx, data from external devices are only received at 9600 baud. Data of such devices will not be transmitted in this protocol.</p>
---	---

### 2.4.8 Demo

The TM250 includes a demonstration mode with which the effect of the different settings can be checked. This mode serves also to illustrate the various functions of the device.

off..... Default setting, this is automatically set after every new system start

on..... Demonstration mode switched on; in the traffic view exemplary traffic targets are indicated

The active demonstration mode is marked in the traffic view by a corresponding symbol:

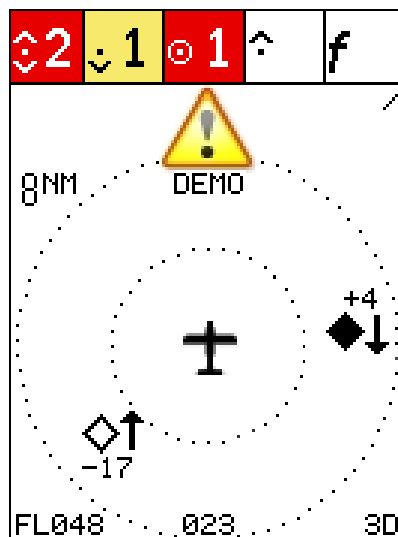

## 2.5 ICAO Configuration Page

With the **MODE** key the configuration view for ICAO can be selected.

In order that ADS-B signals of the own Mode S transponder will not be misinterpreted as one of another traffic object, the TM250 must be initialized before first use. Based on the transponder signals, the TM250 determines which ICAO 24-bit address is assigned to the own aircraft.

During this initialization, the currently received ADS-B messages (position, height, ICAO 24-bit address) are compared with the own GPS position. If an ADS-B signal is received with the same position, this is interpreted as the own one and the ICAO 24-bit address is adopted. The corresponding barometric altitude will be used for comparison with the ADS-B transmission from other traffic objects and thus serves to determine the relative altitude (see 2.3.2).

If the own Mode S transponder is not ADS-B capable, the signal with the greatest field strength is interpreted as the own one. If an own barometric altitude cannot be determined, the absolute height in flight levels (FL) is used for the representation of transport objects instead of relative height values (see 2.3.2).

The described initialization is done under the menu item ICAO:

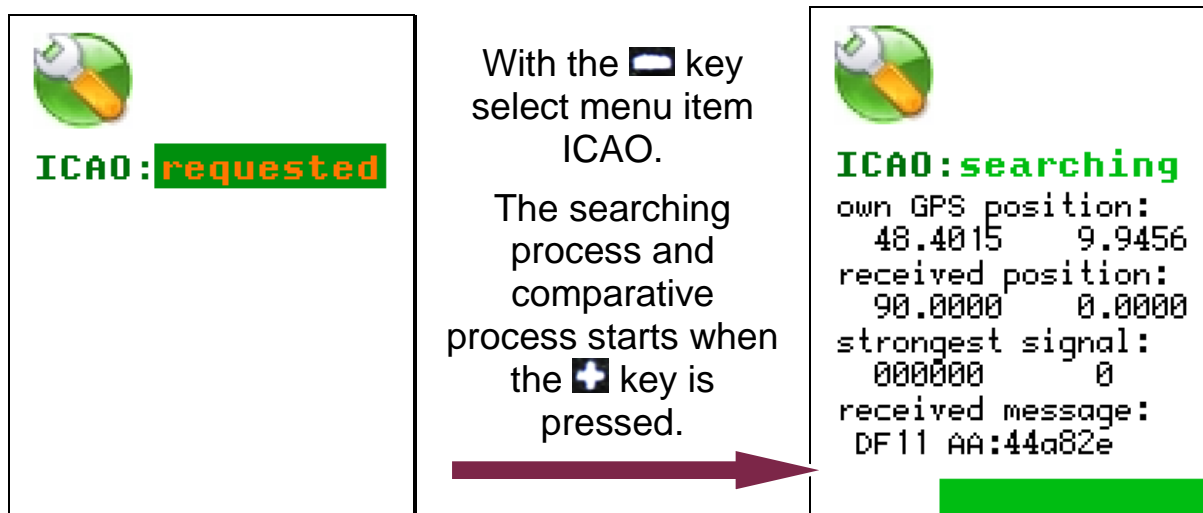

After a successful comparison, the recognized ICAO 24-bit address will be displayed.

Under ICAO following entries can appear:

## Operation and Installation

---

requested	the initialization has not yet occurred
searching	current comparison process, including status information such as external and own position, the detected 24-bit address (eg 3bcdef) and a progress bar will be displayed.
failed	no match found
TRX error	no ADS-B reception
GPS error	no GPS position available

Whether the initialization was successful, can be determined during the operation in the status display (see above) or on the information page (2.6). In the event of a failed initialization there is no valid ICAO 24-bit address displayed and setting of the own ICAO address must be made by yourself on the information page (2.6).

If during multiple automatic searches no valid ICAO address is obtained, you try to change the location of the aircraft. For example, already a nearby hangar or tarmac may prevent the detection.

In flight, the ICAO address must be detected automatically without problems, otherwise the own barometric altitude cannot be determined. Do not make those settings by yourself, but leave this to the copilot.

If the automatic search is not successful in flight, check the settings in the transponder. The transponder must be able to process the TM250 NMEA data at 4800 baud.



Check the automatically determined according to ICAO address on their own!

## 2.6 Information Page



This view provides information about current own aircraft status. The following information is given:

2D/3D..... GPS reception

GPSA..... indicates whether an antenna is connected to the GPS receiver

LAT ..... own position latitude in decimal degree

LON ..... own position longitude in decimal degree

ALT ..... own altitude in feet (ft)



GSP ..... ground speed

TRK..... true track

ICAO ..... own ICAO 24-bit address as transmitted by the Mode S transponder

BARO..... barometric (uncorrected) altitude as transmitted in ADS-B reports by the Mode S transponder, used for altitude comparison with other ADS-B traffic

Furthermore, this page allows to enter the own ICAO 24bit address manually. When the information page is accessed with the **MODE** button, the first digit of the ICAO 24-bit address is highlighted.

By pressing  the digits of the ICAO 24-bit address can be selected in order from left to right. The value at the selected digit can be modified with .

## 2.7 Output of traffic data

To connect an additional display device, the TM250 provides traffic data on pin 8 of the D-Sub socket. Depending on the setting in the configuration menu (see Section 2.4.7), the data are sent at 9600 baud in the "pseudo FLARM<sup>®</sup> protocol" or at 19200 baud in binary format. Use the orange TRAFFIC out cable and connect it to the input of your display device. Connect the black GND wire to the ground connection of your display system.

The specification of the textbased "pseudo FLARM<sup>®</sup> protocol" of this interface is available on request.

## 2.8 Software Update

The TM250 software can be easily updated by the user. Required components comprise:

- Standard Windows PC
- Update-program (available as download within the Service area of [www.funkeavionics.de](http://www.funkeavionics.de))
- USB wire (part of the TM250 delivery)
- TM250

While connecting the TM250 with the PC, the  Button must be pressed and held. The Software can now be updated by running the update program.

### 3 INSTALLATION

#### 3.1 Unpacking and Inspection

Unpack the device carefully. Transport damages must be immediately reported to the carrier. The original packaging material must be kept for proof.

	For storage or return please use the original packaging.
---	--

#### 3.2 Scope of Delivery

Article Number	Explanation/ Details	Cockpit ant. + FAV XPDR	Cockpit ant. + Other XPDR	Body ant. + FAV XPDR	Body ant. + Other XPDR
TM250	Traffic Display TM250	◆	◆	◆	◆
M4X8ZSW (3 pieces)	Mounting screw for panels with a thickness up to 5 mm	◆	◆	◆	◆
DA-1A03B	GPS antenna	◆	◆	◆	◆
TM-USB1	USB cable	◆	◆	◆	◆
03.310.010.71e	Manual „Operation and Installation“	◆	◆	◆	◆

### 3.3 Mounting

- In cooperation with aircraft maintenance, a suitable location and installation method must be determined. All cables can be installed by the maintenance personnel. Suitable cable kits are available from f.u.n.k.e. AVIONICS.
- Avoid installing close to heat sources. Sufficient aerial circulation is necessary.
- When installing the cables and connecting plugs leave enough space for each.
- Sharp bending and routing of wires close to control cables should be avoided.
- The cables must be long enough so that plugs are accessible for repair.
- The cable harness that leads to the device connector must be placed so that condensation water cannot leak into the plug.
- For installation tips and drawings see chapter 3.5.2 "installation tips".
- Inside antenna:
  - While installing an antenna inside the cockpit, take care that the pilot's outside view is not obstructed
  - The antenna should be mounted in such a way that the edges of the antenna are vertically directed
- Outside antenna:
  - The FLARM<sup>®</sup> antenna shall be installed as far as possible from the transponder antenna to avoid that the own transponder signals block the reception of other signals.
  - In most cases, the transponder antenna is installed on the bottom of the aircraft; it is thus recommended to install the FLARM<sup>®</sup> antenna on top of the fuselage.

### 3.4 Connectors

The TM250 includes the following interfaces:

- GPS Antenna
- 1090MHz / FLARM<sup>®</sup> Antenna
- USB
- Power / RS-232 (NMEA output) / RS-232 (external FLARM<sup>®</sup>)

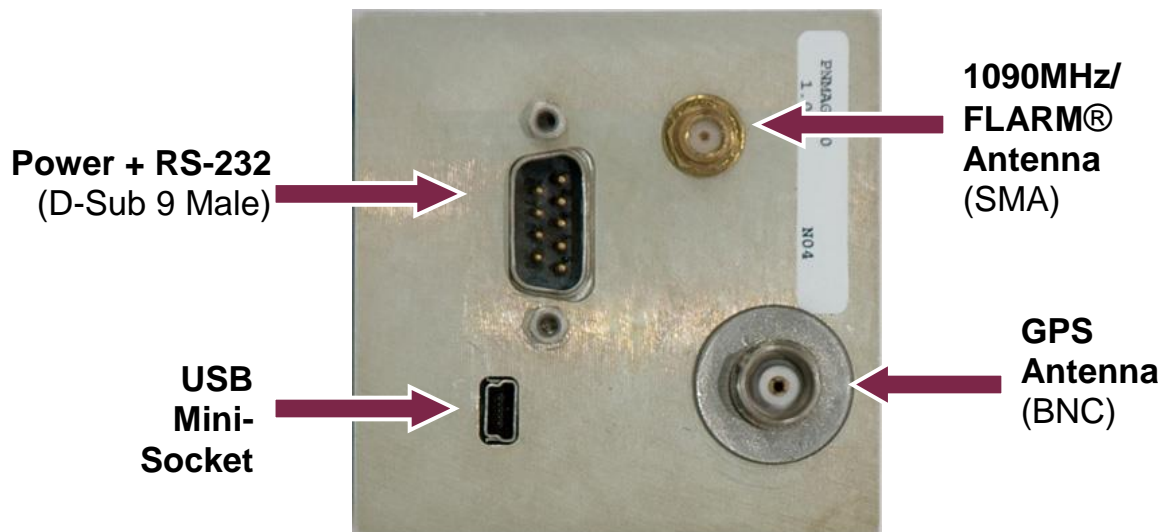

#### 3.4.1 GPS Antenna

A BNC-type socket provides the connection to the active (5V) GPS antenna that is supplied with the TM250.

#### 3.4.2 1090MHz / FLARM<sup>®</sup> Antenna

A SMA-type socket provides the connection to a 1090 MHz antenna. Via this antenna the FLARM<sup>®</sup> signals (868 MHz) are received, as well.

For the antenna there are different options:

- Standard FLARM<sup>®</sup> antenna (flexible, for installation inside the cockpit, PNETAN80, see 3.2 Scope of Delivery)
- GSM rod antenna (for installation on the aircraft's body, PNETAA80, see 3.2 Scope of Delivery)

## Operation and Installation

---

Antennas installed inside the cockpit should still allow a good outside view.

Both antenna types shall be installed vertically and with a large distance to the transponder antenna.

### 3.4.3 USB

Via the USB socket and the USB cable supplied together with the TM250, ADS-B DF17/18 reports that are received by the TM250 can be provided to an external PC in binary format. The USB socket also allows updating the software (see 2.8).

### 3.4.4 Power / RS-232

Through this 9-pole D-Sub socket (male) the TM250 is supplied with power.

In addition, this socket provides the RS-232 signals to connect a TRT800 (A/H) transponder.. With this connection the transponder obtains the NMEA signals from the internal GPS receiver of the TM250 for the transmission of ADS-B reports.



In order to assure the proper transmission of ADS-B signals please make sure that the transponder used is capable to process respective NMEA signals at the respective interface. To achieve this, it might be necessary to change the settings of the transponder (protocol NMEA / 4800 Baud).

Another RS-232 interface allows connecting an external FLARM<sup>®</sup> receiver as well as a display system. (When the USB socket is used, however, this interface is deactivated).

A suitable connection cable is supplied together with the TM250.

Connector Pin-Out			
PIN #	I/O	Term	Function
1	O	Audio Digital	Digital Audio out
2	I	GPS Rx	GPS Receiver Input (for configuration)
3	O	GPS Tx	GPS Receiver Output (NMEA for TRT800)
4	O	Audio Analogue	Analogue-Line Audio out (0,3 V <sub>ss</sub> )
5	I/O	GND	Signal Ground
6	-	Supply PWR	Power Input (9-33 V DC)
7	I	FLARM-Rx	Input from external FLARM
8	O	TRAFFIC-Tx	Traffic data output
9	-	DC-GND	Power Supply Ground

**Rear View:**

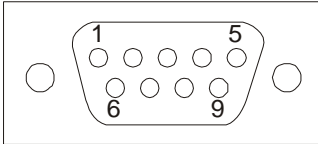

The power supply has the following requirements:

- Voltage: 9 .. 33 V DC
- Current: approx. 0.16A at 13.8 V (2.2 W)

The ON/OFF switch completely disconnects the TM250 from aircraft power, so that the internal electronics can be protected against overvoltage, e.g. during engine start.

## 3.5 Device Dimensions

### 3.5.1 Housing

The TM250 is a device which is to be installed in a cockpit panel with a standard 2-1/4 inch (57 mm) diameter cut-out.



The device has the following dimensions:

Width:	65 mm
Height:	65 mm
Depth:	102 mm (without front plate and connectors)

The built-in display has the following dimensions:

Width:	31.2 mm (visible area)
Height:	41.7 mm (visible area)
Resolution:	132 x 176 pixels
Colors:	65,536

### 3.5.2 Installation Tips

Connection area

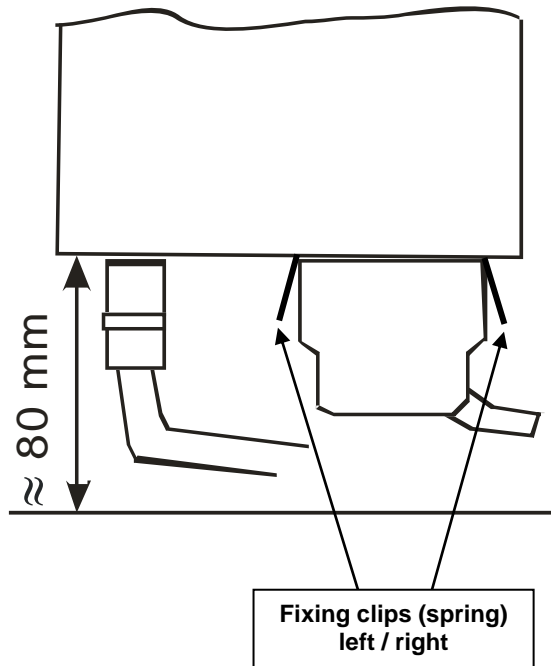

Panel cut out

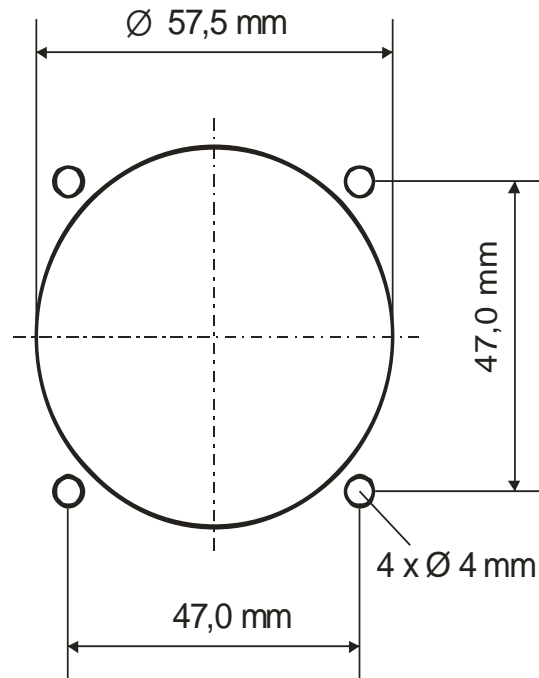

	<p>Connector (plug) has to be clamped with both spring locks</p>
---	--

### 3.6 Post-installation Checks

All control functions of the aircraft must be checked to eliminate risk of interference due to wiring.

### 3.7 Accessories

Additional accessories can be found on the current price-list. Or visit the online shop on [www.funkeavionics.de](http://www.funkeavionics.de).

Article Number	Explanation/ Details	Cockpit ant. + FAV XPDR	Cockpit ant. + Other XPDR	Body ant. + FAV XPDR	Body ant. + Other XPDR
PNETAN80	1090MHz/FLARM® antenna in-cockpit	◆	◆		
PNETAA80	1090MHz/FLARM® antenna body			◆	◆
PNETKA80	Power and data cable - TRT	◆		◆	
PNETKB80	Power and data cable - Other		◆		◆

## 4 APPENDICES

### 4.1 Technical Data

Applied regulations	RTCA DO 260A Change 2
Temperature areas	
Operating	0 °C to +55 °C; for 30 min +70°C
Storage	-30 °C to +85 °C
Power Supply	13,8 VDC (9 VDC .. 33 VDC)  approx. 0.16 Amp. at 13.8 VDC  2,2 W (max)
Protection	external 2 Amp. protection required
Mounting	Installation cut-out diameter 57,5 mm
Weight	280 g

## 4.2 Wiring Diagram

### 4.2.1 Cable Harness for TRT-Serie (XPDR)

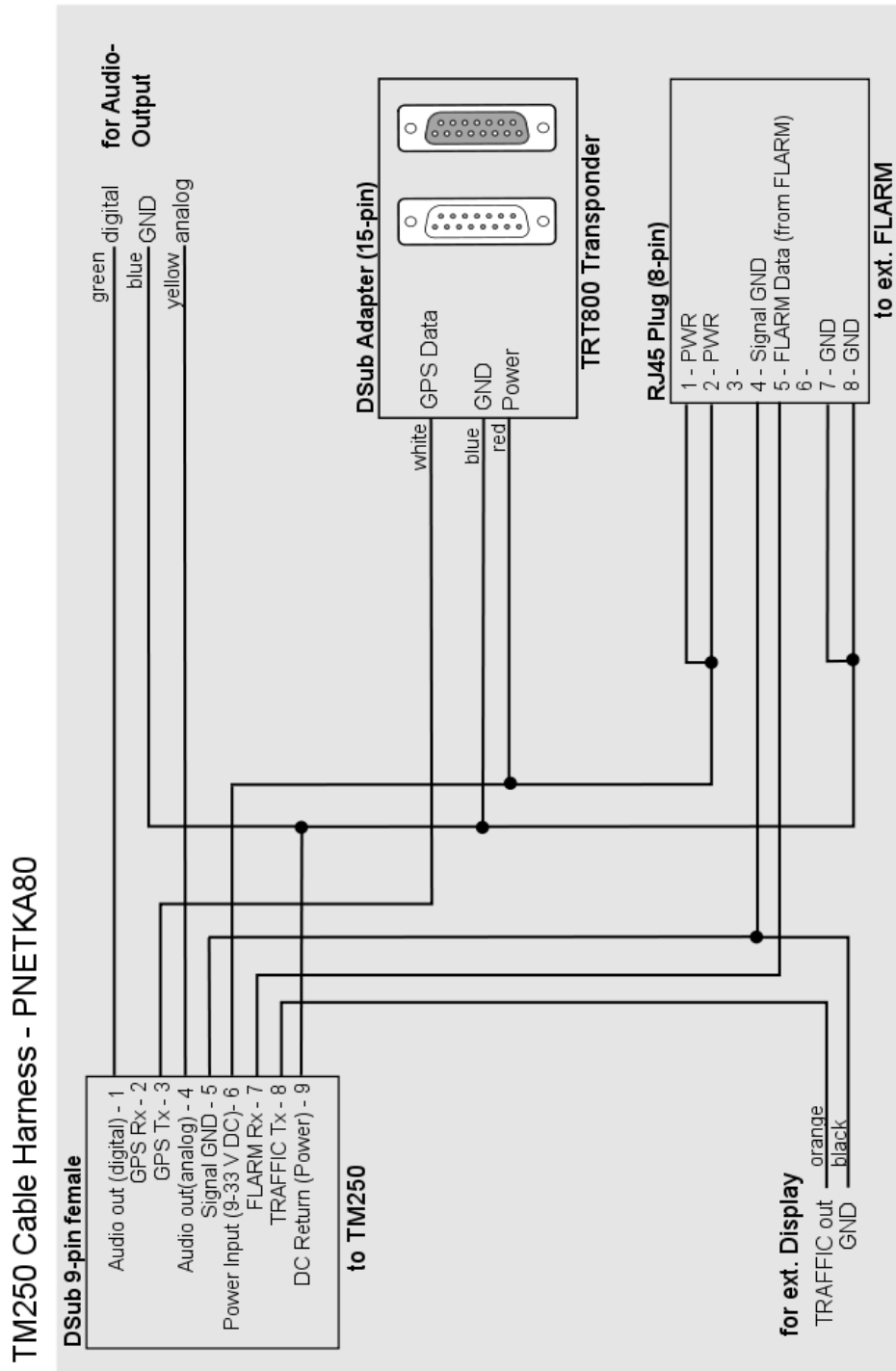

### 4.2.2 Cable Harness for OEM-device (XPDR)

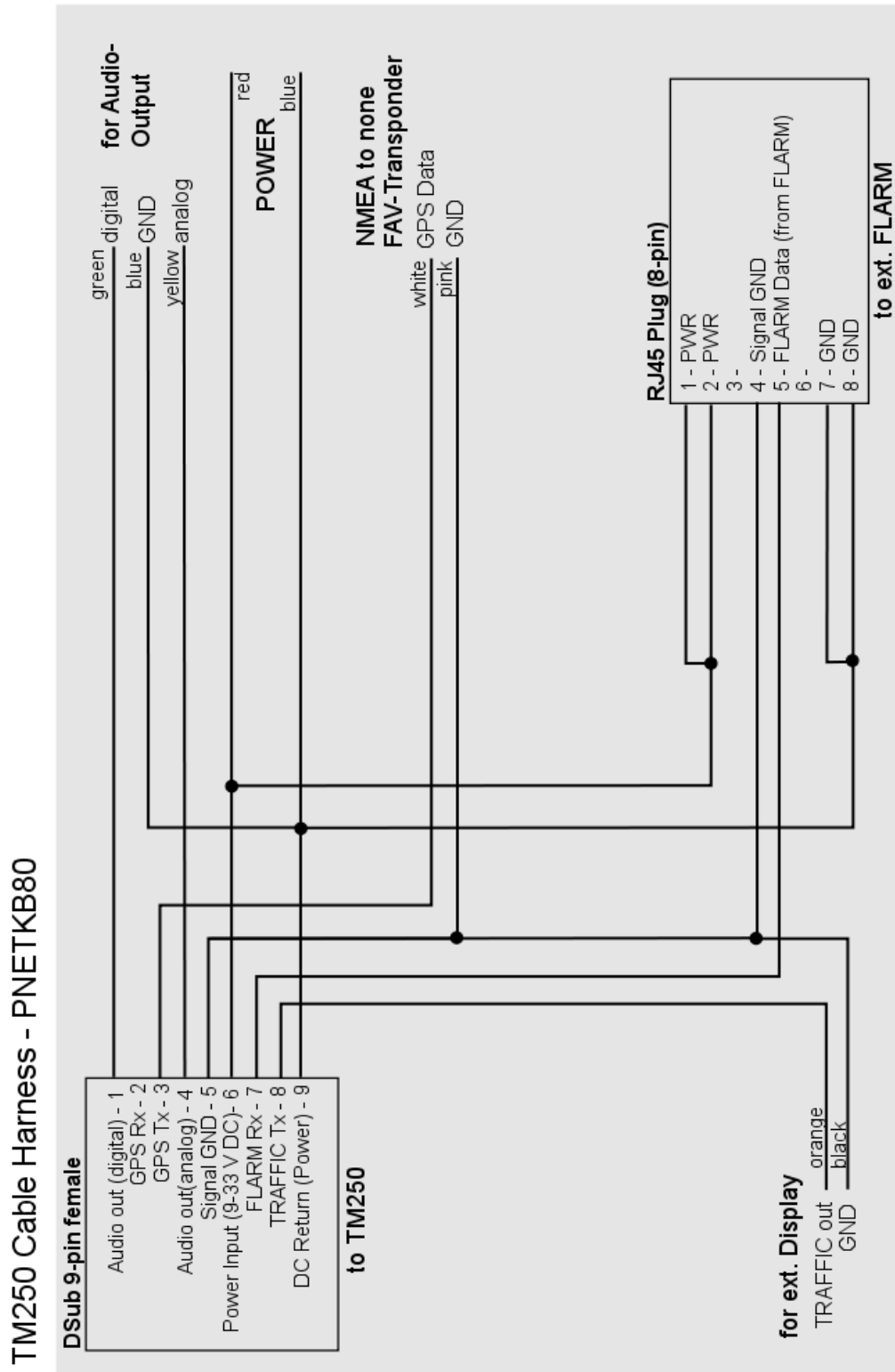

### 4.3 Threat Classifications – Zone Division

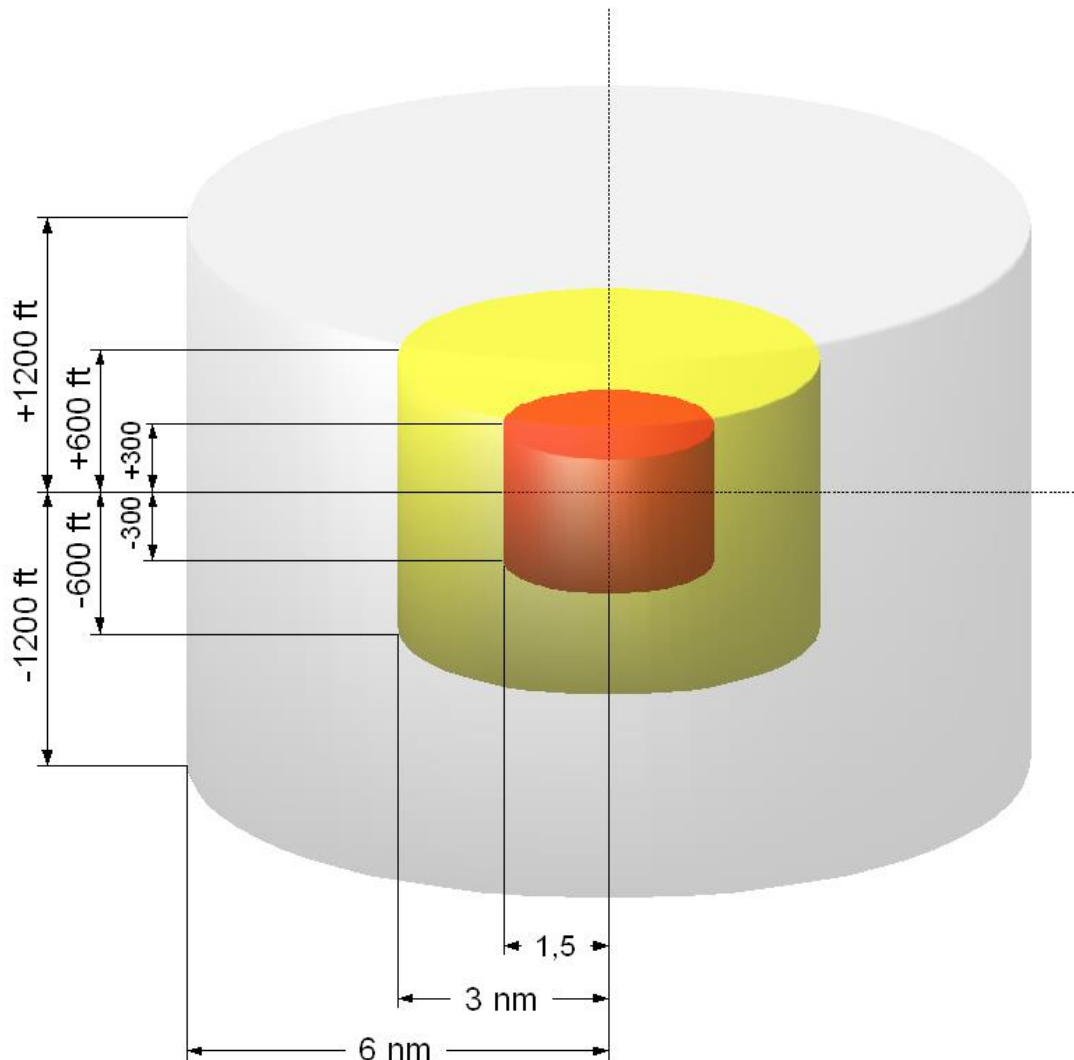



Basically, the collision warning is based on the comparison of the own position with the location of surrounding traffic. With ADS-B traffic, this is done using the respective position reports. For Mode S traffic (not ADS-B capable), the field strength is measured. The proximity of FLARM<sup>®</sup> traffic is detected whenever a signal is received (which suffices as the maximum range of FLARM<sup>®</sup> reception is relatively small).

The priority of a collision warning is determined on the basis of three predefined zones. These are defined in each case by a distance radius as well as by an altitude range around own position.

## Operation and Installation

---

- Zone 1:** If a traffic item closes in to less than 6 NM with an altitude difference (relative altitude) of less than 1200 ft, the first zone is injured. In the traffic display the traffic symbol changes to a filled diamond . This proximity alert does not yet indicate a threat.
- Zone 2:** If a traffic item closes in to less than 3 NM with an altitude difference (relative altitude) of less than 600 ft, the second zone is injured. In the traffic display the traffic symbol changes into a yellow full circle . This classifies the target as a potential threat.
- Zone 3:** If a traffic item is less than 1.5 NM away with an altitude difference (relative altitude) of less than 300 ft, the third and most critical zone is injured. In the traffic display the traffic symbol changes into a red full square . The target is thus classified as an imminent threat that requires immediate action.

Besides the spatial boundaries of these zones, the approach rate is also taken into account.

An alarm equal to the zone 2 violation will be raised if an encounter is forecasted in less than 70 seconds. This will happen regardless of the zone in which the intruder is. (obsolete if target is already inside zone 3).

An alarm equal to the zone 3 violation will be raised if an encounter is forecasted in less than 20 seconds. This happens regardless of the zone in which the intruder is..

For Mode S traffic the measured field strength will be compared to pre-defined threshold values, as well as the flight level (when transmitted). Mode S traffic is using only two zones wherein the zones 1 and 2 are combined into one.

Regarding FLARM<sup>®</sup>, the range of reception is comparable to the zone 2 boundaries.

Notes:



## EG-Konformitätserklärung

EC-Declaration of Conformity  
CE-Déclaration de conformité

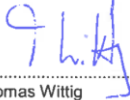
Hersteller / <i>Manufacturer / Fabricant</i>	f.u.n.k.e. AVIONICS GmbH
Anschrift / <i>Address / Adresse</i>	Heinz-Strachowitz-Str. 4 DE-86807 Buchloe Germany
Produktbezeichnung / <i>Product specification / Description du produit</i>	Traffic Monitor
Typen / <i>Types / Types</i>	TM250
Wir erklären in alleiniger Verantwortung, daß das (die) oben bezeichnete Produkt(e) mit folgenden Europäischen Richtlinien übereinstimmt (übereinstimmen) / <i>We declare under our sole responsibility that above product(s) is (are) in conformity with the following directives /</i> <i>Déclarons sous notre seule responsabilité, que le(s) produit(s) repond(ent) aux directives suivantes</i>	2004/108/EG EMV Richtlinie 2004/108/EC EMC Directive 2004/108/CE Directive CEM
Angewandte harmonisierte Normen und technischen Spezifikationen / <i>Applied harmonised standards and technical specifications /</i> <i>Normes harmonisées et spécifications techniques:</i>	EN 55022:2006 + A1:2007 EN 55024:1998 + A1:2001 + A2:2003
Benannte Stelle und Nummer der EG-Baumusterprüfbescheinigung / <i>Notified Body and number of the EC-type-examination certificate /</i> <i>Organisme agréé et numéro du certificate des test CE</i>	n/a
Ort, Datum der Ausstellung / <i>Place, date of issue / Lieu, date de l'édition</i>	Buchloe, 07.01.2014
Revision	3.0
Name und Unterschrift des Befugten / <i>Name and signature of authorized person /</i> <i>Nom et signature de la personne autorisée:</i>	 ..... Dr. Thomas Wittig



## Umweltinformationen für Kunden innerhalb der Europäischen Union

*Regulatory and Compliance/WEEE Legislation within the European Union*

Gemäß der Europäischen Richtlinie 2002/96/EG über Elektro- und Elektronik-Altgeräte (WEEE) und die Änderung 2008/34/EG dürfen Produkte, die direkt am Gerät und/oder an der Verpackung mit diesem Symbol versehen sind, nicht zusammen mit gewöhnlichem Abfall entsorgt werden, sondern sind über die für elektrische und elektronische Geräte zuständigen und von der Regierung oder örtlichen Behörden dazu bestimmten Sammelstellen zu entsorgen. Ordnungsgemäßes Entsorgen und Recyceln trägt dazu bei, potentielle negative Folgen für Umwelt und die menschliche Gesundheit zu vermeiden. Wenn Sie weitere Informationen zur Entsorgung Ihrer Altgeräte benötigen, wenden Sie sich bitte an die örtlichen Behörden oder städtischen Entsorgungsdienste oder an den Händler, bei dem Sie das Produkt erworben haben.

*According to the European directive 2002/96/EC on waste electrical and electronic equipment (WEEE) an the amendment 2008/34/EC: Products, that are marked with the above symbol directly at the device and/or at the packaging, may not to be disposed together with ordinary waste, but have to be disposed using the appropriate differentiated collection centres for electronic and electro waste. Appropriate differentiated waste collection and recycling helps to prevent possible negative environmental and health effects. If you need additional information about the disposal of your products after the end of their working life, please contact your local authorities or municipal waste disposal organisation, or the dealer you have purchased the product from.*

# f.u.n.k.e.

AVIONICS GMBH

## **f.u.n.k.e. AVIONICS GmbH**

Heinz-Strachowitz-Str. 4  
DE-86807 Buchloe  
Germany

phone.: +49-8241 80066 0

fax.: +49-8241 80066 99

E-mail:

[service@funkeavionics.de](mailto:service@funkeavionics.de)

[www.funkeavionics.de](http://www.funkeavionics.de)